



16744 WEST PARK CIRCLE DRIVE
CHAGRIN FALLS, OH. 44023
PH (440) 543-2393 FAX (440) 543-2397
www.qubeinc.com
steve@qubeinc.com

800 747 8381

Computer Enclosures





QUBE CORPORATION
16744 WEST PARK CIRCLE DRIVE
CHAGRIN FALLS, OH. 44023
PH (440) 543-2393 FAX (440)543-2397
www.qubeinc.com

Email: steve@qubeinc.com

STANDARD TERMS

VERBAL ORDERS ARE NOT ACCEPTED : Because of the number of sizes and details involved, we require that all orders be confirmed in writing prior to manufacture. This is typically done via FAX OR EMAIL

CREDIT TERMS Qube's terms are **2% 10 Net 30** Credit must be established prior to shipment, and prior to programming of custom and dimensionally changed product. We also accept **Master Card , Visa, and American Express**

FREIGHT CHARGES : are prepaid and added on most shipments. Customer specified carriers may be shipped collect.

UPS SHIPMENTS: Please be aware that Qube will ship certain sizes UPS based on customer request and cost. In many cases, UPS adds a **DIMENSIONAL WEIGHT** charge in excess of normal zone / weight costs. These costs are added to the shipment freight charges.

OVERNIGHT AIR: **All expedited shipments require a third party billing (such as customers UPS or Federal Express number)**. UPS has certain dimensional limits, FED EX will accept larger freight. For certain large enclosures, overnight air is not available. All expedited freight requires a written authorization from the customer.

FREIGHT DAMAGE : Unfortunately, freight damage is common in the shipment of enclosures. Qube makes every attempt to package its products accordingly.. **PLEASE INSPECT FREIGHT PRIOR TO ACCEPTING** .If concealed damage occurs, please retain the damaged product, and notify Qube for instruction. Often a lid or other part can simply be replaced.

LEAD TIMES: QUBE DOES NOT STOCK ANY PRODUCT. Our manufacturing process allows dimensional changes and the ability to manufacture enclosure sizes not commonly available. Most HC,SC,and TR products ship in 5 *working* days or less. Large cabinets generally ship in 15 *working* days or less. CN computer enclosures generally ship in 5-7 working days. Most initial custom orders are shipped in 20 working days or less.

PRODUCT RETURNS : Custom and dimensionally changed products **may not** be returned. Standard products may be returned as in salable condition. and the return request is made within 30 days of product shipment. On multiple unit custom orders we recommend that 1 unit be produced prior to manufacturing the entire order.

COUNTRY OF ORIGIN : All Qube products are produced in Chagrin Falls OH, USA

LIMITED WARRANTY

Qube Corporation warrants product to be manufactured as specified, and free from defects in material and workmanship. No representation or other affirmation of facts, including but not limited to statements regarding capacity, suitability for use or performance, shall be deemed to be a warranty or representation of Qube Corporation for any purpose.

MADE IN THE USA





16744 WEST PARK CIRCLE DRIVE
CHAGRIN FALLS, OH. 44023
PH (440) 543-2393 FAX (440)543-2397
www.qubeinc.com
Email: steve@qubeinc.com



About us

Qube corporation manufacturers standard and custom computer and kiosk enclosures using industrial grade ABS plastic. We also manufacture printer enclosures .A full line of PVC electrical enclosures is also available

The company is located in Chagrin Falls OH, an eastern suburb of Cleveland OH.

Our Advantage

Our process allows for easy dimensional changes and customization at low volumes with short lead times. Our products offer substantial savings when compared to stainless steel.

WIRELESS ROUTER ENCLOSURES	Page 2
COMPUTER CONSOLES	Page 3
TABLE TOP NEMA 4X COMPUTER CABINET	Page 4
WALL MOUNT COMPUTER ENCLOSURE	Page 5
CPU ENCLOSURES	Page 6
MONITOR AND TOUCH SCREEN ENCLOSURES	Page 7
DVR ENCLOSURE	Page 8
KIOSK	Page 9
PRINTER / COMPUTER CONSOLE	Page 10

QWE WIRELESS ROUTER ENCLOSURES

Qube wireless enclosures provide security for wireless access points. Plastic allows signal transmission. Indoor model is manufactured using .250" thick Black ABS . A Latched outdoor version, with rain resistant vent is made using .250" thick white UV stabilized Polyethylene . Both units are locking, with all locks being keyed the same.

CUSTOMIZATION

Any dimension can be changed. Other customization options include heated enclosures , enclosures with fans, internal mounting plates , and specific cutouts for external antennas. Heated enclosures are also available

PART #	Description
QWE121204-502	Black ABS, Indoor wall mount
QWE141204-401	White HDPE, Outdoor wall mount

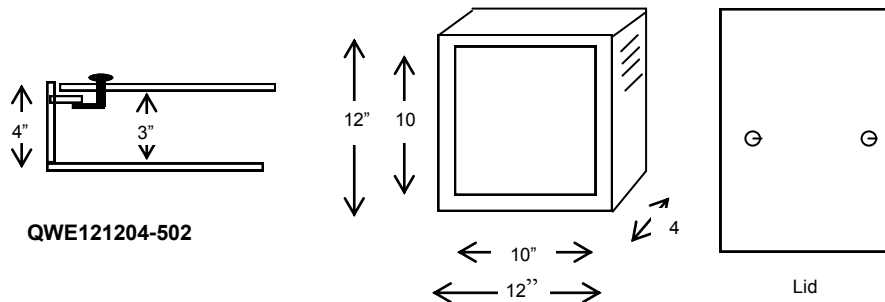

QWE121204-502

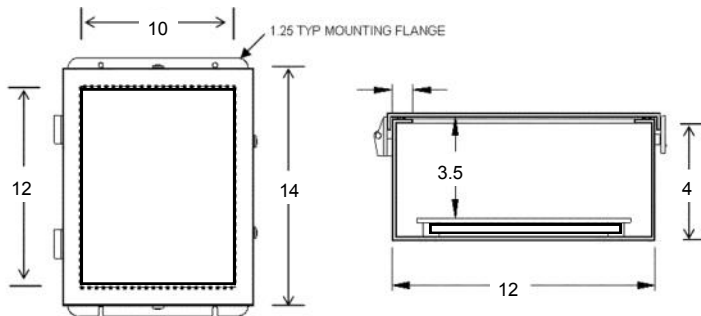

QWE141204-401



CN CONSOLE

NEMA 12 /NEMA 4X COMPUTER CONSOLES

Computer Consoles which provide Nema 12 protection with an Internal Locking Pull-Out Keyboard tray. Fan and filter kit is INCLUDED. Unit comes with either skid plates or casters, PLEASE SPECIFY when ordering. The CN1500 is the same as the CN1200, but with out the Fan/filter which provides Nema 4X (washdown) protection. Black ABS plastic is corrosion resistant and provides a significant savings option when compared to stainless steel.

The CN622424-502 provides Nema 12 protection and accommodates a flat screen monitor. A writing surface is integral to the design.

ITEM #	COLOR / MATERIAL
CN1200-502	BLACK ABS Nema 12
CN1500-502	BLACK ABS Nema 4X
CN622424-502	BLACK ABS Nema 12

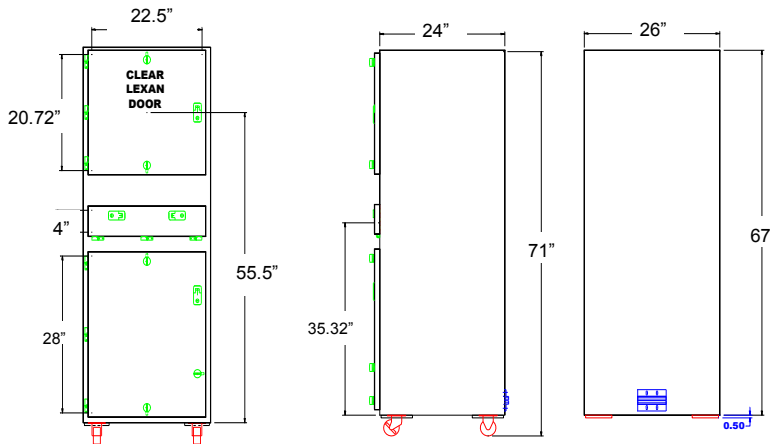

CN1200 / 1500-502



CN622424-502

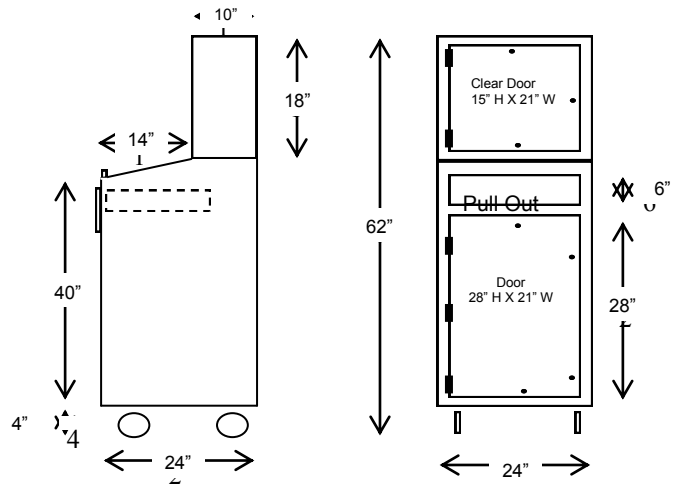

CN650 TABLE TOP Nema 4X COMPUTER CABINET

4X Table or bench top computer/monitor enclosure with pull out keyboard tray. The unit comes with a fan/filter with water resistant cover.

The product is standard in Black ABS plastic,

An optional heater is available for low temp applications.

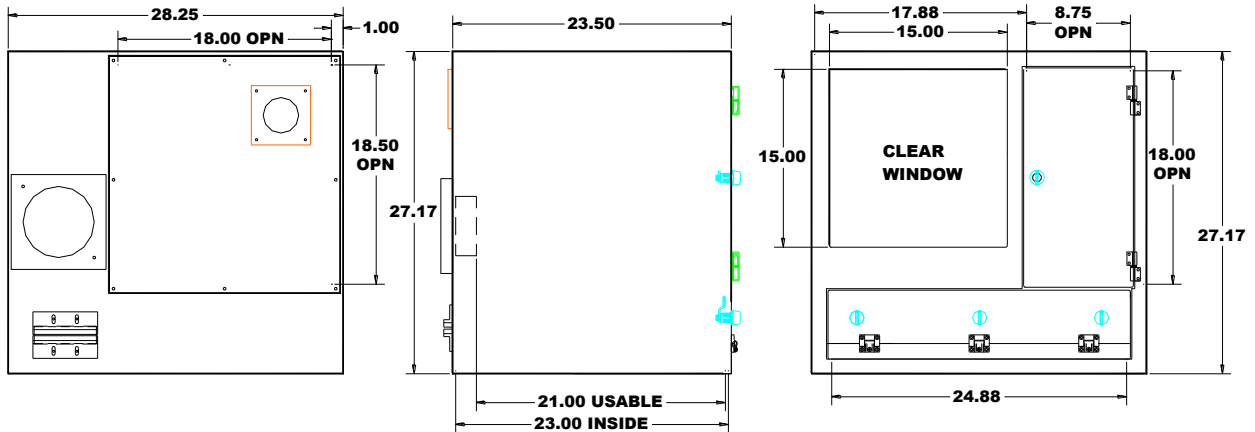
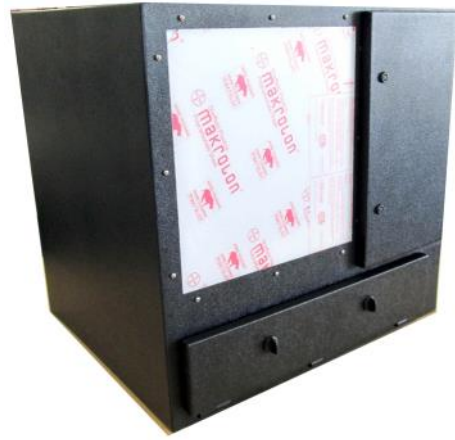

REAR VIEW

SIDE VIEW

FRONT VIEW

Qube wall mount computer monitor enclosures provide nema 12 and 4X protection for monitors and have pull out keyboard trays. They can accommodate all in one computers. The mounting brackets are detachable, so units could be table top or pedestal mounted.

ITEM #	COLOR / MATERIAL
CNW302624-502	BLACK ABS Nema 4X
CNW302614	BLACK ABS Nema 4X

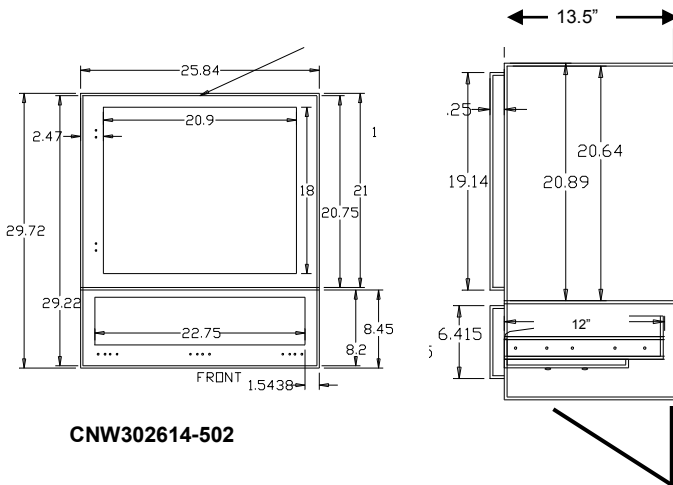
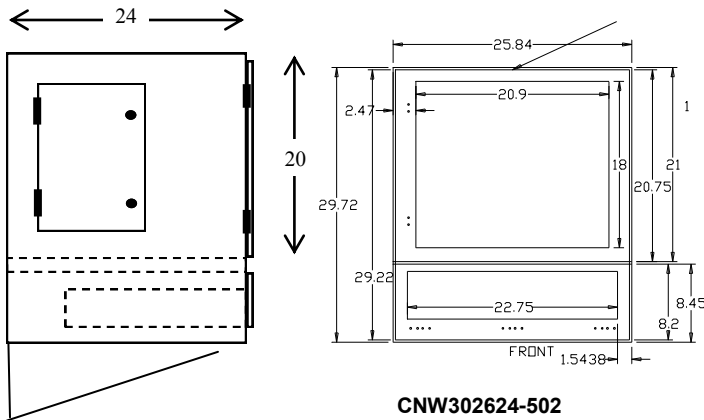

CN490 CN500 BLACK ABS CPU ENCLOSURES

Nema 12 CPU only enclosure. A Nema 4X version for washdown is available as a CN550. Flush locking door is Clear Polycarbonate. Enclosure material is .250" thick black abs plastic



Part #	COLOR	Overall Dimensions			Fits CPU Up To		
		H	W	D	H	W	D
CN490 - 502	BLACK	21.5"	12.5"	23"	17"	8.5"	19"
CN500 - 502	BLACK	27.5"	14"	26"	23"	10"	22"

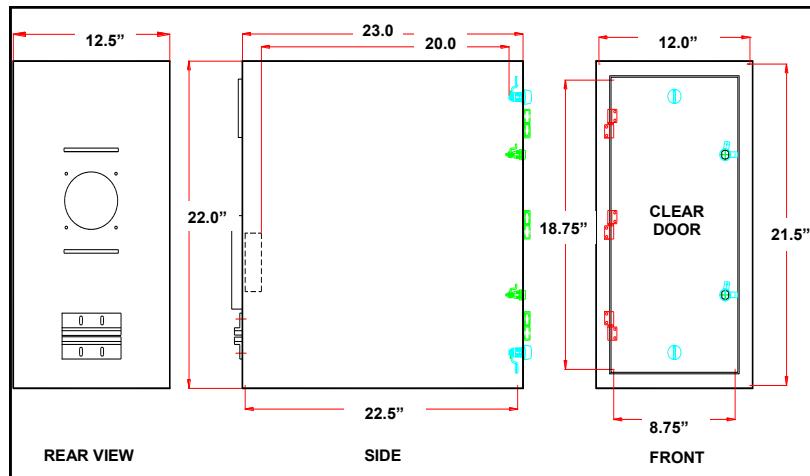

CN490

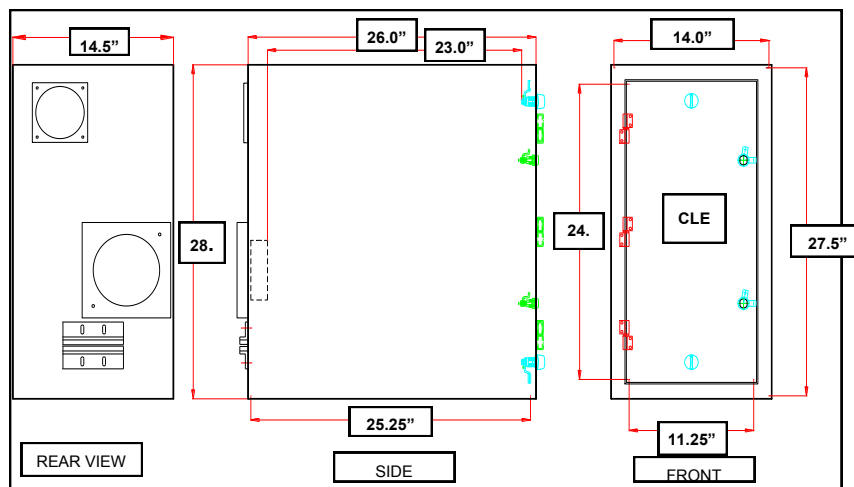

CN500

CNM BLACK ABS PLASTIC MONITOR ONLY ENCLOSURE

Qube monitor enclosures provide either nema 12 (dust and dirt) or Nema 4X (corrosion resistance/washdown) protection. One type monitor enclosure is for typical flat screen monitor on a stand. The style available is for touch screen monitors. The touch screen monitor enclosure design utilizes a front plate which screws on after the touch screen is mounted.

Both styles of monitor enclosures can be wall mounted with the addition of brackets.

ITEM #	COLOR / MATERIAL
CNM202412-502	BLACK ABS Nema 12
CNM202412-### LAST 3 DIGITS WILL DENOT SPECIFIC MONITOR	BLACK ABS Nema 12

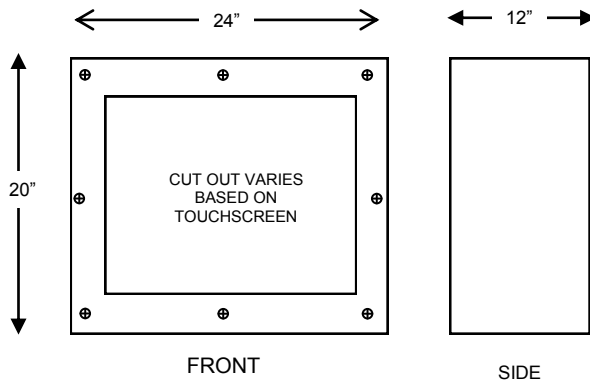
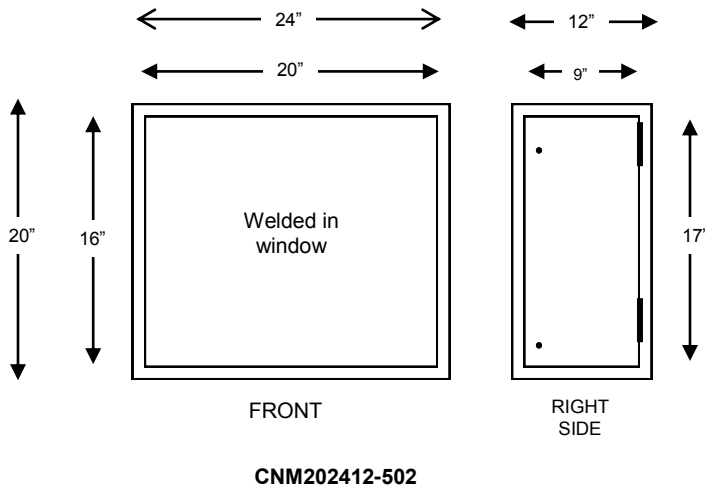

DVR BLACK ABS PLASTIC DVR ENCLOSURE

DVR cabinets protect recorders in dusty or washdown environments. Design includes smoked acrylic front and security locks.

Product can be configured and dimensioned for specific needs. Product shown is wall mounted, with removable wall brackets.

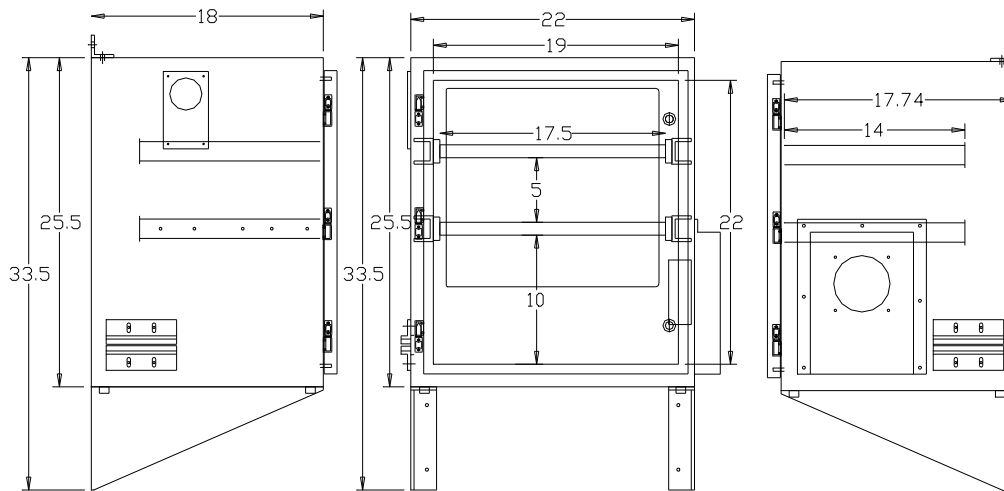

PGA222218-502

KIOSK ABS PLASTIC KIOSK ENCLOSURE

Custom designed kiosk enclosures for interactive applications and industrial touch screen installations. All kiosk projects are based on customer specific hardware. Qube only manufactures enclosures for these applications. We can customize the enclosure based on the equipment being integrated. Examples include printers, card readers, keyboards, and scanners.

Our advantage is that our process allows quick development in small quantities.

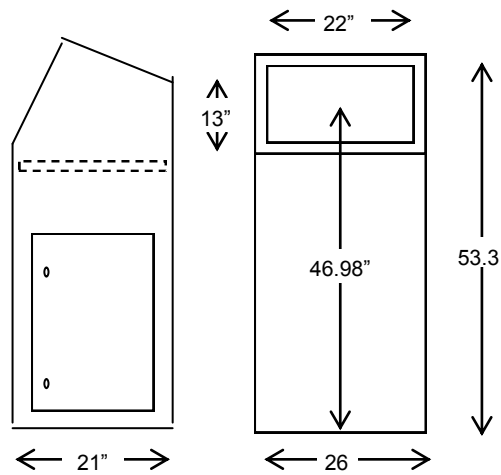

Typical Dimensions, which can be changed. Doors, can be on the front back or side

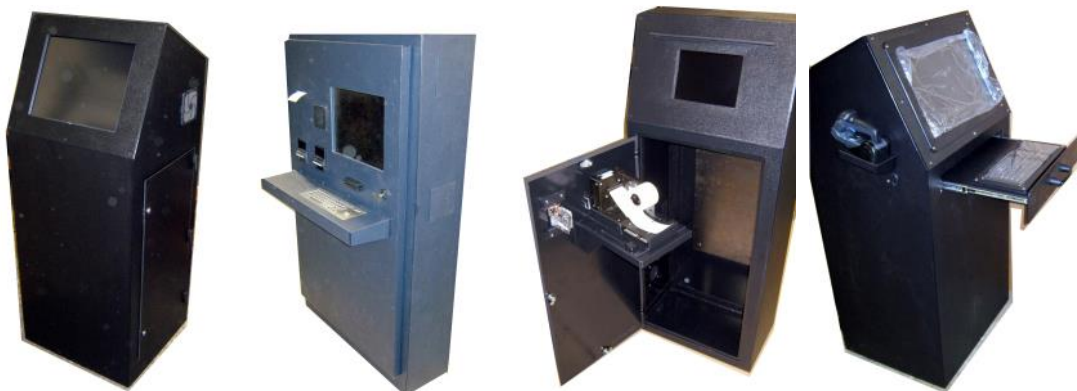

Examples of Industrial Kiosks

